

RADIO CONTROLLED ELECTRIC RACING BOAT

Model 95641

ASSEMBLY AND OPERATION INSTRUCTIONS



Due to continuing improvements, actual product may differ slightly from the product described herein.

Distributed exclusively by Harbor Freight Tools.

3491 Mission Oaks Blvd., Camarillo, CA 93011

Visit our website at: <http://www.harborfreight.com>

**TO PREVENT SERIOUS INJURY, READ AND UNDER-
STAND ALL WARNINGS AND INSTRUCTIONS BEFORE USE.**

Copyright© 2006 by Harbor Freight Tools®. All rights reserved. No portion of this manual or any artwork contained herein may be reproduced in any shape or form without the express written consent of Harbor Freight Tools.

For technical questions or replacement parts, please call 1-800-444-3353.

SPECIFICATIONS

Boat Battery	7.2 V, 1800 mAh, NiMH
Charger	Input: 120 V~, Output: 9 VDC
Transmitter Batteries Required	8 "AA" batteries (sold separately)
Radio Control Frequencies	26.995 MHz, 27.045 MHz, 27.095 MHz, 27.125 MHz, 27.145 MHz, 27.175 MHz
Control Range	up to 400'
Run Time	10-20 minutes per full charge

Save This Manual

You will need this manual for the safety warnings and precautions, assembly, operating, inspection, maintenance and cleaning procedures, parts list and assembly diagram. Keep your invoice with this manual. Write the invoice number on the inside of the front cover. Write the product's serial number in the back of the manual near the assembly diagram, or write month and year of purchase if product has no serial number. Keep this manual and invoice in a safe and dry place for future reference.

GENERAL SAFETY RULES

▲WARNING!

READ AND UNDERSTAND ALL INSTRUCTIONS
Failure to follow all instructions listed below may result in
electric shock, fire, and/or serious injury.
SAVE THESE INSTRUCTIONS

WORK AREA

1. **Keep your work area clean and well lit.** Cluttered benches and dark areas invite accidents.
2. **Do not operate R/C Electric Racing Boat in explosive atmospheres, such as in the presence of flammable liquids, gases, or dust.** Radio Control electronics may create sparks which may ignite the dust or fumes.
3. **Keep bystanders and visitors away while operating.** Distractions can cause you to lose control. Protect others in the area from rapidly spinning propellers. Provide barriers or shields as needed.

ELECTRICAL SAFETY

1. **Grounded tools must be plugged into an outlet properly installed and grounded in accordance with all codes and ordinances. Never remove the**

grounding prong or modify the plug in any way. Do not use any adapter plugs. Check with a qualified electrician if you are in doubt as to whether the outlet is properly grounded. If the tools should electrically malfunction or break down, grounding provides a low resistance path to carry electricity away from the user.

2. **Double insulated tools are equipped with a polarized plug (one blade is wider than the other). This plug will fit in a polarized outlet only one way. If the plug does not fit fully in the outlet, reverse the plug. If it still does not fit, contact a qualified electrician to install a polarized outlet. Do not change the plug in any way.** Double insulation eliminates the need for the three wire grounded power cord and grounded power supply system.
3. **Do not abuse the Power Cord. Never use the Power Cord to carry the tools or pull the Plug from an outlet. Keep the Power Cord away from heat, oil, sharp edges, or moving parts. Replace damaged Power Cords immediately.** Damaged Power Cords increase the risk of electric shock.
4. **When operating a power tool outside, use an outdoor extension cord marked “W-A” or “W”.** These extension cords are rated for outdoor use, and reduce the risk of electric shock.

PERSONAL SAFETY

1. **Stay alert. Watch what you are doing, and use common sense when operating this R/C Electric Racing Boat. Do not use while tired or under the influence of drugs, alcohol, or medication.** A moment of inattention while operating may result in serious personal injury.
2. **Dress properly. Do not wear loose clothing or jewelry. Contain long hair. Keep your hair, clothing, and gloves away from moving parts.** Loose clothes, jewelry, or long hair can be caught in propellers.
3. **Avoid accidental starting. Be sure the Power Switch is off before plugging in.** Carrying this R/C Electric Racing Boat with your finger on the Power Switch invites accidents.
4. **Do not overreach. Keep proper footing and balance at all times.** Proper footing and balance enables better control.
5. **Use safety equipment. Always wear eye protection.** Always wear ANSI-approved safety goggles and work gloves when using or performing maintenance on this product.

PRODUCT USE AND CARE

1. **Do not use the R/C Electric Racing Boat if the Power Switch does not turn it on or off.** Any tool that cannot be controlled with the Power Switch is dangerous and must be replaced.
2. **Disconnect the Power Cord Plug from the power source before making any adjustments, changing accessories, or storing the R/C Electric Racing Boat.** Such preventive safety measures reduce the risk of starting accidentally. **Always unplug from its electrical outlet before performing any inspection, maintenance, or cleaning procedures.**
3. **Store out of reach of children and other untrained persons.** Never allow Children to come in contact with this product.
4. **Maintain with care and keep clean.** Properly maintained, this product is easier to control. Do not use if damaged in any way. Tag and “Do not use” until repaired.
5. **Check for misalignment or binding of moving parts, breakage of parts, and any other condition that may affect the R/C Electric Racing Boat’s operation. If damaged, have it serviced before using.** Many accidents are caused by poor maintenance.
6. **Use only accessories that are recommended by the manufacturer for your model.** Accessories that may be suitable for one product may become hazardous when used on another.

SERVICE

1. **Product service must be performed only by qualified repair personnel.** Service or maintenance performed by unqualified personnel could result in a risk of injury.
2. **When servicing this product, use only identical replacement parts. Follow instructions in the “*Inspection, Maintenance, And Cleaning*” section of this manual.** Use of unauthorized parts or failure to follow maintenance instructions may create a risk of electric shock or injury.

SPECIFIC SAFETY RULES

1. **Maintain labels and nameplates on the product.** These carry important information. If unreadable or missing, contact Harbor Freight Tools for a replacement.
2. **Maintain a safe working environment.** Make sure there is adequate surrounding workspace.
3. **Always keep all electrical cords away from the propellers on this R/C Electric Racing Boat.**

4. **If two Boats with the same radio frequency are used (both with the same numbers on the Transmitter and/or Receiver), they must be at least 1640' away from one another in order to maintain adequate transmission control.**
5. **Before using in the water perform a distance check to be certain that you can maintain radio control at least 25' from Transmitter to Boat with the Antenna collapsed.**
6. **NEVER run R/C Electric Racing Boat in swimming pools or bodies of water where people are swimming or playing.**
7. **NEVER recharge non-rechargeable batteries.**
8. **Use only batteries of the type recommended.** Do not mix old and new batteries.
9. **Remove batteries from both the R/C Electric Racing Boat and the Transmitter if they will not be used for a long period.**
10. **People with pacemakers should consult their physician before using this product.** Electromagnetic fields in close proximity to a heart pacemaker could cause interference to or failure of the pacemaker. In addition, people with pacemakers should adhere to the following:
 - Avoid operating this R/C Electric Racing Boat alone.
 - Don't use this product with the power switch locked on.
 - If powered via a power cord be certain that the tool is properly grounded. A ground fault interrupt (GFCI) system is also a good precaution. This inexpensive device is a good safety measure because it prevents a sustained electrical shock.
 - Properly maintain and inspect all tools before use to avoid electrical shock.
11. **Never pick up, or lay down the R/C Electric Racing Boat until its Propellers come to a complete stop.** Moving parts can grab the surface and pull the R/C Electric Racing Boat out of your control and there is the possibility of damage, or personal injury. When handling this Racing Boat, be sure to keep hands clear of propellers at all times.
12. **This product is for supervised use by ages 6 and up.** Children must be properly trained in safety issues and operating procedures before being allowed to use this product and must always be supervised by a responsible adult.
13. **Never leave the R/C Electric Racing Boat unattended when it is plugged into its charger.** Turn off the R/C Electronic Racing Boat and unplug it from its electrical outlet before leaving. **WARNING: Always remove the Battery Pack (16) from the Battery Compartment when it is being charged.**
14. **Always wear work gloves if removing the Propellers (4A and/or 4B).** The blades can be very sharp. If the R/C Electric Racing Boat has been recently used,

let the Twin 380 Motors (8A and 8B) as well as both Drive Shafts (6B and 6C) cool at least 15 minutes before touching.

15. **Do not recharge the Battery Pack (16) if it is hot.**

GROUNDING

⚠WARNING!

Improperly connecting the grounding wire can result in the risk of electric shock. Check with a qualified electrician if you are in doubt as to whether the outlet is properly grounded. Do not modify the power cord plug provided with the tool. Never remove the grounding prong from the plug. Do not use the tool if the power cord or plug is damaged. If damaged, have it repaired by a service facility before use. If the plug will not fit the outlet, have a proper outlet installed by a qualified electrician.

GROUNDING TOOLS: TOOLS WITH THREE PRONG PLUGS

1. Tools marked with “Grounding Required” have a three wire cord and three prong grounding plug. The plug must be connected to a properly grounded outlet. If the tool should electrically malfunction or break down, grounding provides a low resistance path to carry electricity away from the user, reducing the risk of electric shock. **(See 3-Prong Plug and Outlet.)**
2. The grounding prong in the plug is connected through the green wire inside the cord to the grounding system in the tool. The green wire in the cord must be the only wire connected to the tool’s grounding system and must never be attached to an electrically “live” terminal. **(See 3-Prong Plug and Outlet.)**
3. Your tool must be plugged into an appropriate outlet, properly installed and grounded in accordance with all codes and ordinances. The plug and outlet should look like those in the following illustration. **(See 3-Prong Plug and Outlet.)**

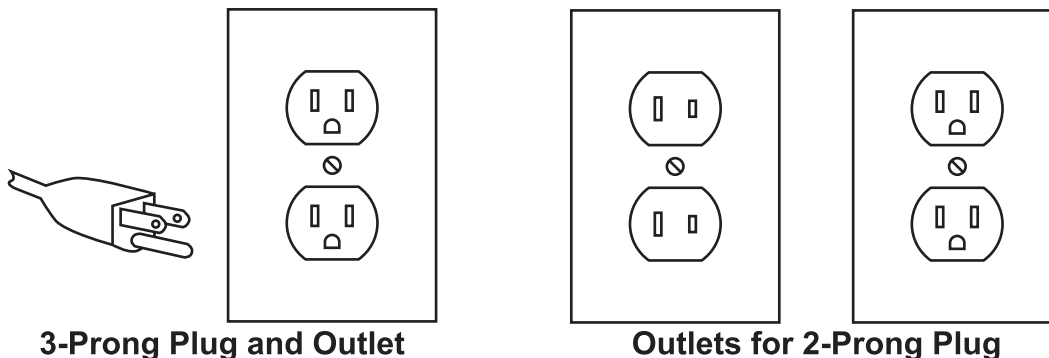

DOUBLE INSULATED TOOLS: TOOLS WITH TWO PRONG PLUGS

Note: The Charger included with this R/C Electronic Racing Boat has a 2-Pronged plug.

1. Tools marked “Double Insulated” do not require grounding. They have a special double insulation system which satisfies OSHA requirements and complies with the applicable standards of Underwriters Laboratories, Inc., the Canadian Standard Association, and the National Electrical Code. **(See Outlets for 2-Prong Plug.)**
2. Double insulated tools may be used in either of the 120 volt outlets shown in the preceding illustration. **(See Outlets for 2-Prong Plug.)**







EXTENSION CORDS

1. **Grounded** tools require a three wire extension cord. **Double Insulated** tools can use either a two or three wire extension cord.
2. As the distance from the supply outlet increases, you must use a heavier gauge extension cord. Using extension cords with inadequately sized wire causes a serious drop in voltage, resulting in loss of power and possible tool damage. **(See Table A.)**
3. When using more than one extension cord to make up the total length, make sure each cord contains at least the minimum wire size required. **(See Table A.)**
4. If you are using an extension cord outdoors, make sure it is marked with the suffix “W-A” (“W” in Canada) to indicate it is acceptable for outdoor use.
5. Make sure your extension cord is properly wired and in good electrical condition. Always replace a damaged extension cord or have it repaired by a qualified electrician before using it.

RECOMMENDED MINIMUM WIRE GAUGE FOR EXTENSION CORDS* (120 OR 240 VOLT)					
NAMEPLATE AMPERES (at full load)	EXTENSION CORD LENGTH				
	25 Feet	50 Feet	75 Feet	100 Feet	150 Feet
0 – 2.0	18	18	18	18	16
2.1 – 3.4	18	18	18	16	14
3.5 – 5.0	18	18	16	14	12
5.1 – 7.0	18	16	14	12	12
7.1 – 12.0	18	14	12	10	-
12.1 – 16.0	14	12	10	-	-
16.1 – 20.0	12	10	-	-	-

TABLE A * Based on limiting the line voltage drop to five volts at 150% of the rated amperes.

Symbology

	Double Insulated
	Canadian Standards Association
	Underwriters Laboratories, Inc.
	Volts Alternating Current
	Amperes
	No Load Revolutions per Minute (RPM)

UNPACKING

When unpacking, check to make sure that the item is intact and undamaged. If any parts are missing or broken, please call Harbor Freight Tools at the number shown on the cover page of this manual as soon as possible.

Note: Save the box and all Styrofoam packing that comes with this R/C Electronic Racing Boat. It is helpful for safe, secure storage when it is not in use.

ASSEMBLY INSTRUCTIONS

Note: For additional information regarding the parts listed in the following pages, refer to the Assembly Diagram on page 15 of this manual.

1. **⚠WARNING!** Make sure the Power Switch of the Transmitter (20) is in its "OFF" position and that the R/C Electric Racing Boat is unplugged from its electrical outlet before making any adjustments.
2. Remove the R/C Electric Racing Boat, the Transmitter and all parts from the box. Check to make sure everything is included as per the parts list on page 14 in this manual.

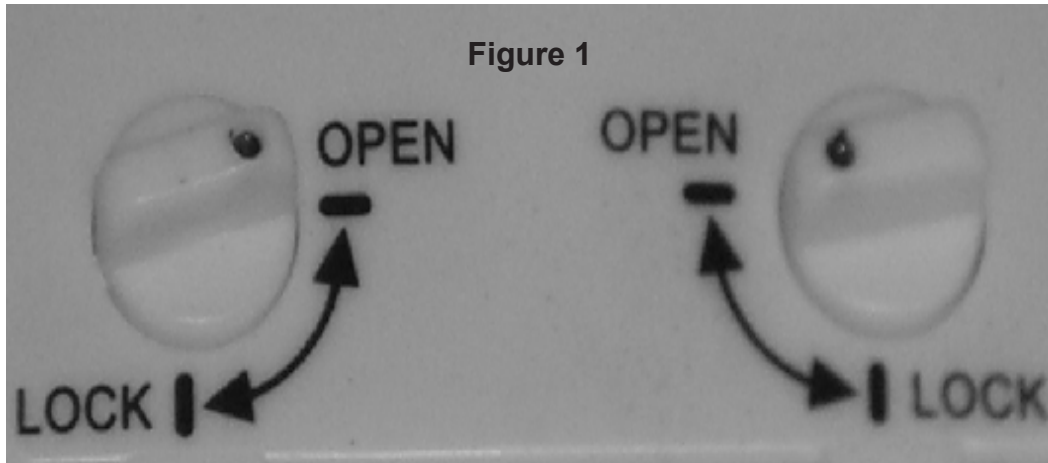

3. Remove the Deck Cabin (1) by twisting the two Buttons at the back of the Deck Cabin (1) to OPEN. This will expose the Battery Compartment. See **Figure 1**.

Note: There is another Button for locking and unlocking the Deck Cabin (1) and it is located on the front section of the Deck Cabin (1). It is not shown in **Figure 1**. Be sure it is also locked before using the R/C Electric Racing Boat.

Figure 2

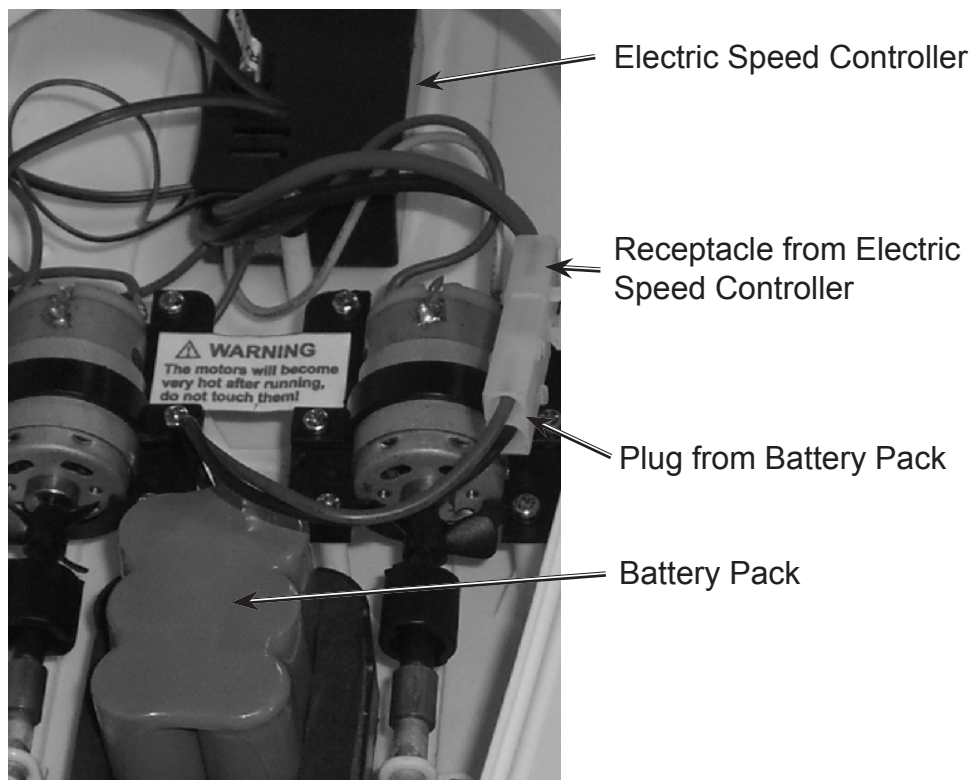

4. If the Battery Pack (16) is plugged into the Electric Speed Controller (18), unplug them and remove the Battery Pack (16) from the Battery Compartment so it may be charged completely. See **Figure 2**.

Note: The Rechargeable Battery should be charged fully before its first use in order to get maximum run-time for your R/C Electric Racing Boat. See Charging Instructions on page 10.

5. After fully charging the Battery Pack (16) replace it into the Battery Compartment and plug it into the Electric Speed Controller (18).
6. Replace the Deck Cabin (1) and lock it into place with the two Lock Buttons at the rear.
7. Install the Antenna Tube (3) over the string Antenna that dangles from the right rear of the Hull (2). See assembly diagram on page 15.
8. Make sure the Power Switch on the Transmitter (20) is in the OFF position. Open the Battery Compartment located on the bottom of the Transmitter (20). Insert new 8 AA Batteries (not included) making sure positive and negative ends are facing in the correct direction. Replace the Transmitter Battery Compartment cover.
9. After reading the Operation Instructions carefully you may launch your R/C Electric Racing Boat.

Note: See photo on page 16 of this manual for complete idea of inside Hull layout.

CHARGING THE BATTERY

1. Plug the Charger (17) into a 120V wall outlet, or into an extension cord that is connected to a 120V outlet.
2. After removing the Battery Pack (16) from the Battery Compartment under the Deck Cabin (1), plug the Battery Pack (16) into the Charger (17).

Note: Do not force the connectors as they will only connect one way. Charge the batteries only when they are cool.

3. Charging time is approximately 3.5 to 5 Hours for totally discharged Battery Pack (16), but charging time may be reduced if the Battery Pack (16) is not fully discharged.
4. When Charging is completed, re-insert the Battery Pack (16) into the Battery Compartment and fasten down the Deck Cabin (1) using the two lock buttons at the back of the Deck Cabin (1) and one at the front.

WARNING

To prevent serious injury from fire or battery explosion:

DO NOT CHARGE FOR MORE THAN 5 HOURS! The charger will not turn off or stop charging when the battery is fully charged. Disconnect battery from charger when battery gets hot. Overcharging can damage the Battery Pack and can pose a fire hazard!

OPERATION INSTRUCTIONS

USING THE TRANSMITTER TO STEER

Note: See **Figure 3** for Transmitter (20) layout.

1. When you push the Throttle Lever on the Transmitter (20) forward, the Twin Propellers will rotate at the same time and speed pushing the Racing Boat forward.
2. When you move the Steering Lever to the left, the Right Propeller will rotate faster and the Racing Boat will turn left..
3. When you move the Steering Lever to the right, the Left Propeller will rotate faster turning the Racing Boat to the right.

Figure 3
Transmitter

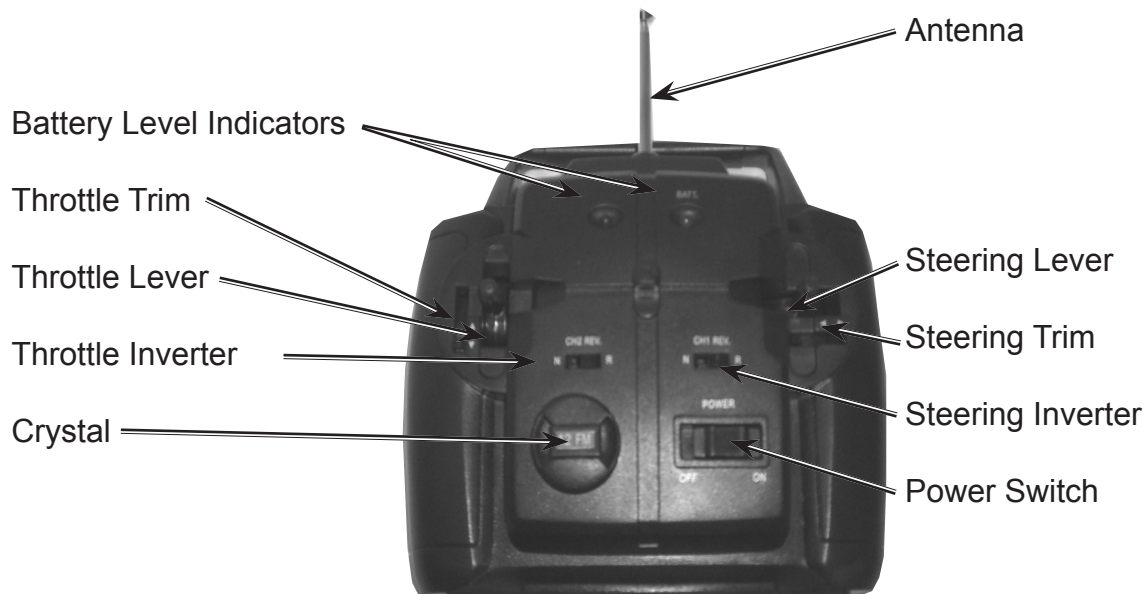

4. **The Transmitter layout is as follows:**
 - a. **Battery Level Indicators:** Green light means Transmitter Batteries are strong. If Red light is flashing and a beeping is heard, replace the 8 AA Batteries at once.
 - b. **Throttle Trim:** Adjusts the Throttle in small increments so the R/C Electric Racing Boat will not move when the Throttle is at it's minimum position.
 - c. **Throttle Lever:** Controls the speed of the R/C Electric Racing Boat and it's movement forward.
 - d. **Inverter Buttons:** Used for changing direction for steering. This boat cannot travel in reverse, however.

- e. **Crystal:** This shows the channel you are transmitting on. You can order crystals in different channels in order to race with other boats without transmission interference.
- f. **Steering Lever:** Used to turn R/C Electric Racing Boat to the left or right.
- g. **Steering Trim:** Used to make slight adjustments in order to keep Boat on straight path if Steering Lever is not being used.
- h. **Power Switch:** On - Off button. Make sure it is always in the OFF position before picking up the R/C Electric Racing Boat.

USING THE RADIO CONTROLLED ELECTRIC RACING BOAT

1. With the Transmitter Power Switch and the boat power switch both in the OFF position, place the Racing Boat in the water pointed away from the edge of the water space.
2. Move the Power Switch to ON and gently push the Throttle Lever forward to move the Racing Boat forward.
3. At first using low speeds practice turning and making the Racing Boat react to the commands of the Transmitter.
4. Set the Throttle Trim and the Steering Trim before increasing speeds.
5. Be aware of the time. Do not run out of power while the Racing Boat is located far away from the launch area. Once the power is depleted the Racing Boat will stop.
6. Always make sure you are away from others while using your R/C Electric Racing Boat in order to prevent accidents and/or personal injury.

INSPECTION, MAINTENANCE, AND CLEANING

⚠WARNING! Make sure the Power Switch of the R/C Electric Racing Boat is in its “OFF” position and it is unplugged from its electrical outlet before performing any inspection, maintenance, or cleaning procedures.

1. **BEFORE EACH USE**, inspect the general condition. Check for loose screws, misalignment or binding of moving parts, cracked or broken parts, damaged electrical wiring, and any other condition that may affect its safe operation. If abnormal noise or vibration occurs, have the problem corrected before further use. **Do not use damaged equipment.**
2. **AFTER EACH USE**, inspect the Racing Boat’s transmission shaft and bearing for water. Water may accumulate after each use, resulting in rust or blocked transmission shaft. Dry the transmission shaft by taking the propeller down, unscrewing and removing the shaft struts and drying the shaft and strut bearings. Adding lubricant to the shaft and bearings will also help prevent rust. Once done, reinstall all pieces.

Changing Boat Frequency

- a. Turn off the boat and the remote control.
- b. Open the tabs of the boat cover and unscrew the electric speed controller housing.
- c. Lightly hold down the circuit board and replace the crystal.
- d. Screw down the electric speed controller housing and lock the top cover of the boat with the tabs.
- e. Pull out and replace the crystal on the controller to match the crystal in the boat. The controller will only control the boat if it has the same frequency.

Troubleshooting

Problem	Possible Causes	Probable Solutions
R/C Electric Racing Boat will not start	<ol style="list-style-type: none"> 1. Low Transmitter Batteries. 2. Battery Pack (16) not connected to the Electric Speed Controller (18). 	<ol style="list-style-type: none"> 1. Change the old 8-AA Batteries in Transmitter (20) for new ones. 2. Remove the Deck Cabin (1) and make sure the Battery Pack (16) is properly connected to the Electronic Speed Controller (18) Refer to Figure 2.
R/C Electric Racing Boat will not steer straight or follow turning commands correctly	One, or possibly both of the Propellers (4A and 4B) are damaged or possibly fouled with debris.	Turn off all power and check both Propellers (4A and 4B) for damage or fouling and if necessary, replace one or both.

Problem	Possible Causes	Probable Solutions
R/C Electric Racing Boat moves or turns without any commands from your transmitter.	<ol style="list-style-type: none"> 1. Low Transmitter Batteries. 2. Someone else is operating a Radio Controlled device in the area. 	<ol style="list-style-type: none"> 1. Change the old 8-AA Batteries in Transmitter (20) for new ones. 2. Change frequency crystals on your Transmitter (20) and boat.

PARTS LIST

Part	Description	Q'ty
1	Deck Cabin	1
2	Hull	1
3	Antenna Tube	1
4	Shaft Strut	2
4A/4B	Left and Right Propellers	1 ea
5	Shaft Housing	2
6A/6B	Left and Right Drive Shafts	1 ea
6C	Shaft Coupling	1
7A	Motor Shaft Adaptor	1
7B/7C	Left and Right Motor Fans	1 ea
8A/8B	Left and Right 380 Motors	1 ea
9	Motor Retainer	1

Part	Description	Q'ty
10	Motor Housing Screws	4
11	Electric Speed Controller Housing	1
12	Electric Speed Controller Screw	1
13	Motor Housings	2
14	Battery Box	1
15	Battery Box Screws	2
16	Battery Pack	1
17	Charger	1
18	Electric Speed Controller	1
19	Crystal Set	1
20	Transmitter	1

PLEASE READ THE FOLLOWING CAREFULLY

THE MANUFACTURER AND/OR DISTRIBUTOR HAS PROVIDED THE PARTS LIST AND ASSEMBLY DIAGRAM IN THIS MANUAL AS A REFERENCE TOOL ONLY. NEITHER THE MANUFACTURER OR DISTRIBUTOR MAKES ANY REPRESENTATION OR WARRANTY OF ANY KIND TO THE BUYER THAT HE OR SHE IS QUALIFIED TO MAKE ANY REPAIRS TO THE PRODUCT, OR THAT HE OR SHE IS QUALIFIED TO REPLACE ANY PARTS OF THE PRODUCT. IN FACT, THE MANUFACTURER AND/OR DISTRIBUTOR EXPRESSLY STATES THAT ALL REPAIRS AND PARTS REPLACEMENTS SHOULD BE UNDERTAKEN BY CERTIFIED AND LICENSED TECHNICIANS, AND NOT BY THE BUYER. THE BUYER ASSUMES ALL RISK AND LIABILITY ARISING OUT OF HIS OR HER REPAIRS TO THE ORIGINAL PRODUCT OR REPLACEMENT PARTS THERETO, OR ARISING OUT OF HIS OR HER INSTALLATION OF REPLACEMENT PARTS THERETO.

ASSEMBLY DIAGRAM

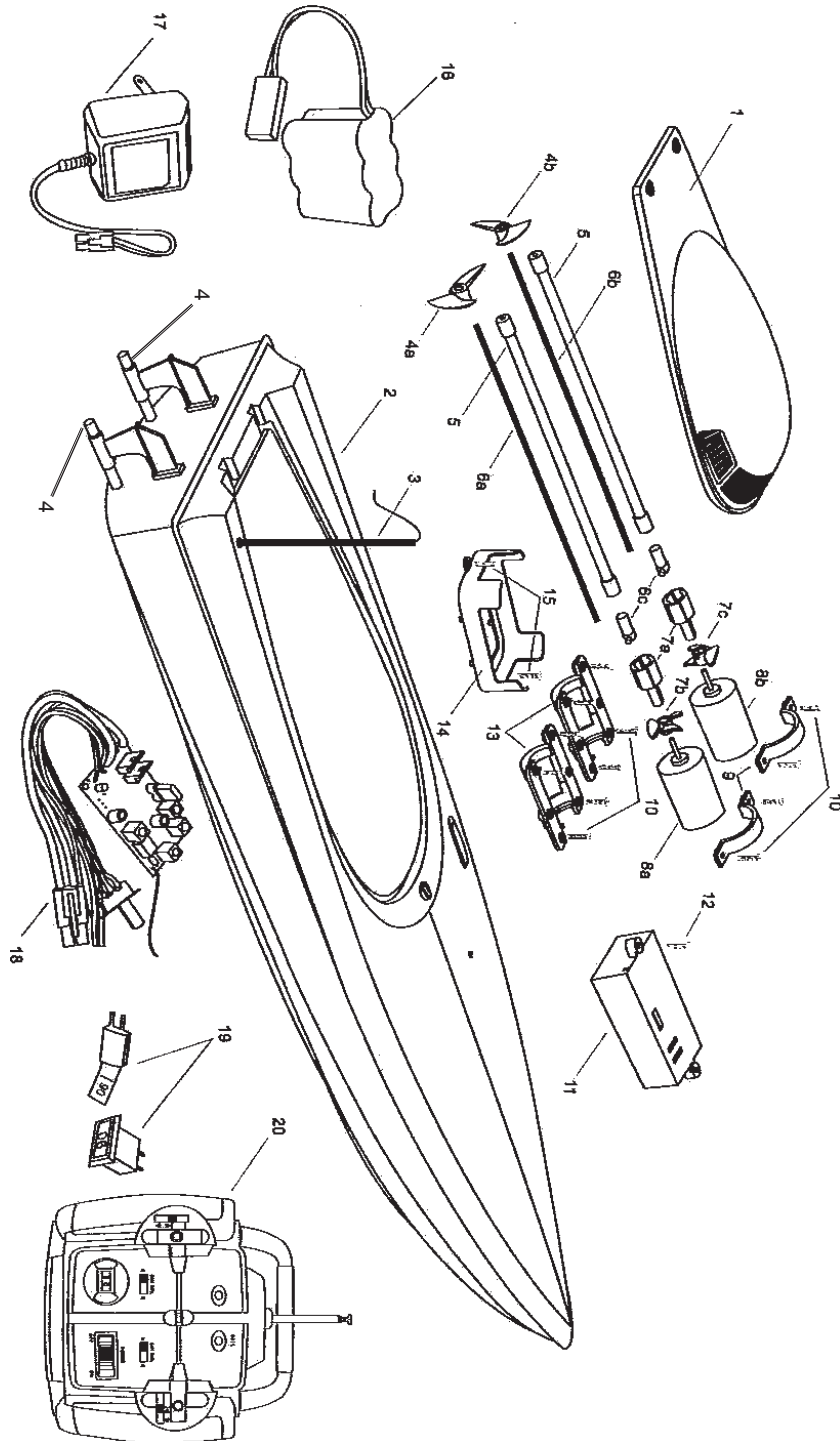

Record Product's Serial Number Here: _____

Note: If product has no serial number, record month and year of purchase instead.

Note: Some parts are listed and shown for illustration purposes only, and are not available individually as replacement parts.

INTERIOR OF CABIN LAYOUT

